



Questions, call : 1-800-MOTO-USA

<http://www.cannondale.com/motorsports>

## Cannondale Motorsports Service Bulletin

BULLETIN : SB02-006

MODELS : 2002 C440 up to and including VIN 5B6BC21C32B000115

ISSUED : 3/26/02

SUBJECT : Incorrect routing, steering head

CONDITION : The front number plate on a small number of C440s was installed so that the throttle cable and front brake line were routed on the wrong sides of the small tab holding the number plate to the upper triple clamp. This routing of throttle cable and front brake line is incorrect and can result in damage to the throttle cable and/or front brake line.

### WARNING

**Damage to either the throttle cable or brake line can result in the operator losing the ability to control the vehicle and be severely injured or killed in an accident.**

SOLUTION : Inspect that the front number plate is mounted with the throttle cable on the vehicle left side of the upper plate mounting tab and make sure the front brake line is on the vehicle right side of the mounting tab. See "C440 Correct Routing (Steering Head)" on page 2 of this service bulletin. Correct the routing if necessary. Remove the front number plate upper mounting bolt and position each cable as indicated in the illustration. If the cables were routed incorrectly, thoroughly inspect the cables and harness leads for any damage that might have occurred (e.g, bending, kinks, pinching or abrasion) and take corrective action. Reinstall the upper front number panel bolt when complete. Check the vehicle controls for proper function.

PARTS : No parts required.

**If you have any questions about this service bulletin, call toll free 1-800-MOTO-USA.**

## C440 CORRECT ROUTING (STEERING HEAD)

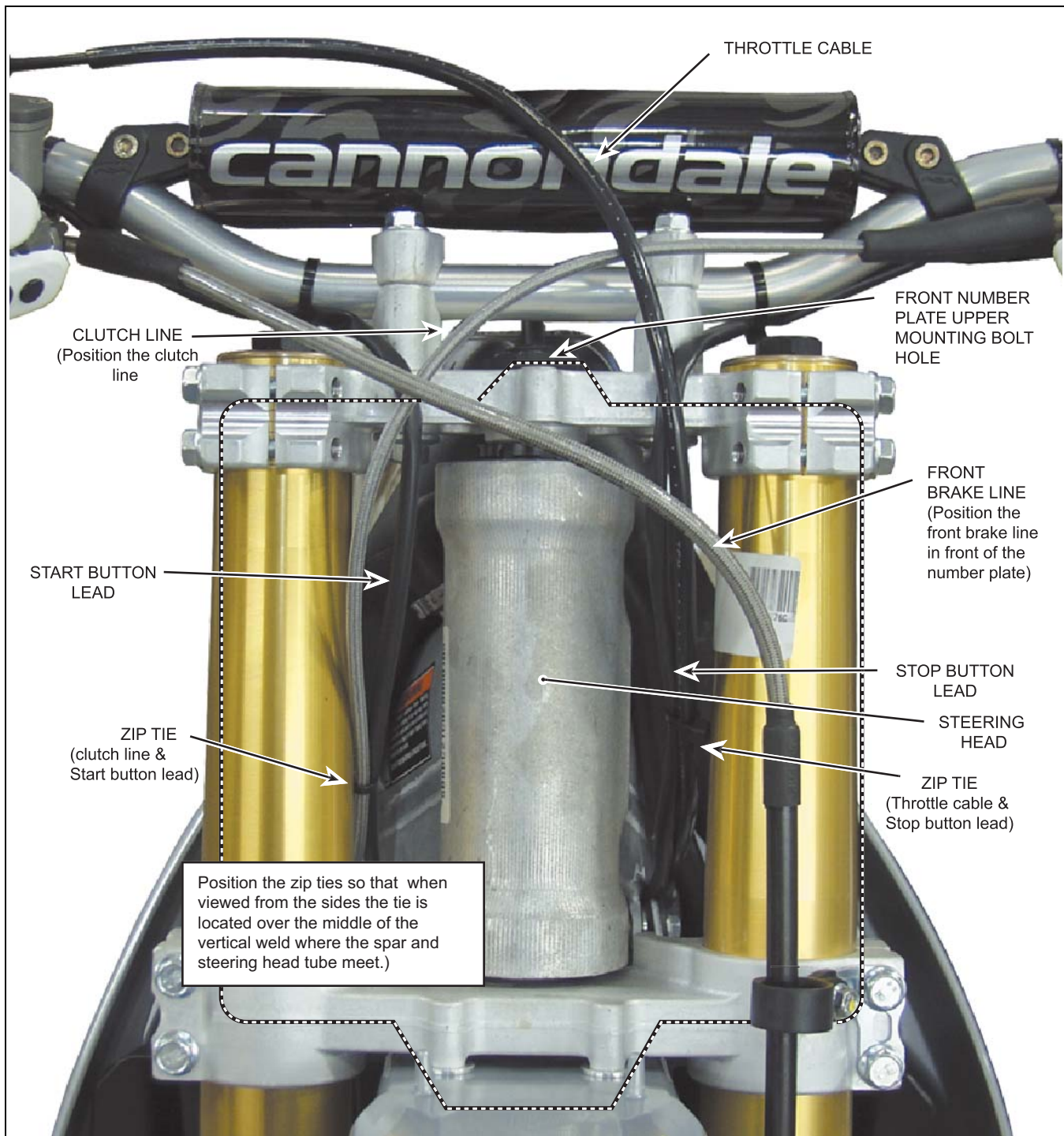

The photo above shows the correct routing and identity of the cables and lines in the steering head area. The front number plate (represented by the dotted line ) has been removed in this photo for clarity.

### NOTE :

*The front brake line is routed in front of the installed front number plate.*

*Notice the location of the upper front number panel mounting hole in the upper triple clamp.*